

Taurian[®]MPS

WHEELER

A Taurian Brand



WHEELER TWINCORE

WHEELER



20 Years of Experience

Start to Success, Together

With over 20 years of expertise, Taurian™ has established itself as a leading Indian manufacturer of crushing and screening equipment for aggregates, mining, and mineral processing. The name Taurian™ stands for excellence and reliability globally.

Founded by industry experts, Taurian™ has evolved from a family business to India's only public limited company in its field. Focused on long-term value and quick ROI, Taurian™ has strategic partners with top U.S. and European firms to deliver superior products that meet global industry standards.

Whether you're an experienced veteran or new to the industry, Taurian™ offers extensive support to the global aggregate market through its leading brands, including Taurian MPS™, Terratrak™, Cyclowash™, and Stackmax™.

WHEELER

The Wheeler Series is Taurian's range of mobile, wheeled crushing and screening solutions, built for fast setup, easy transport, and reliable performance. Designed to handle diverse applications in mining, quarrying, and infrastructure, the series delivers consistent, high-quality output while minimizing downtime.

Durable, efficient, and versatile, Wheeler machines keep your operations productive — wherever the job takes you.



The Taurian MPS - Wheeler Product Range

WHEELER JAW
Semi-Mobile Jaw Crushers

WHEELER CONE
Semi-Mobile Cone Crushers

WHEELER IMPACTOR - VSI
Semi-Mobile VSI

WHEELER IMPACTOR - HSI
Semi-Mobile HSI

WHEELER HYPERSCREEN
Semi-Mobile Screening Systems

WHEELER TWINCORE
Semi-Mobile 2 Stage Plant

Hopper / Feeder:

- Capacity: 8.2m³ (10.72 cu. yd.)
- Hydraulic folding hopper sides
- Wear resistant steel on hopper sides

Vibratory Drive Mechanism

- Frequency ~600–1200 RPM; amplitude via eccentric weights or electromagnetic drives.
- Shafts/bearings are high-strength steel for continuous load handling.

Grizzly Bars

- Bar spacing ~2–6 inches to remove fines before crushing.
- Typically built from manganese steel or carbide overlays.

Hardox lined feed chute

- It efficiently manages the coarsest materials
- Pitman eye protection plate provides additional protection

Easy wedge adjustment system

- It allows quick CSS setting without shim plates Adjustments are mechanical as standard A fully automatic hydraulic option for easy CSS settings is also available I

Protection plates

- Protection plates behind the jaw dies protect the steel castings against wear

Singular piston cup design

- 250-bar piston cup ensures responsive control.
- Low maintenance design enhances efficiency.
- Optimized crushing performance for superior results.

Floating Shaft Benefits

- Shaft supported at both top and bottom for stability.
- Ideal for high-durability, reliable applications.

Side Conveyor (Finesize)

- Width: 900mm (36")
- Discharge height: 4.3m (14'2")
- Variable speed control

Maintenance-Friendly Design

- Modular MV vibrators and cardan shafts for easy replacement.
- Increase space between decks for easy maintenance.
- Modular rubber liners at feedbox, discharge spouts, and cardan shaft for optimal service life.

General

- Available in 2, 3, or 4 deck configurations
- Adjustable slope angle (12° to 22°)
- Shaft lines connected by a cardan shaft.
- Adjustable modular rails, cross member protection
- Tensioned and heavy-duty bolted panels



WHEELER

WHEELER TWINCORE - Two Crushers. One Solution.

The Taurian Wheeler TwinCore 100 combines a primary jaw and secondary cone crusher on a single wheeled chassis for high-capacity, precision two-stage crushing. With its TGF1042-2D feeder, TJ 100 jaw, TC series cone, and integrated screen, it delivers consistent, high-quality output with minimal setup time. Built tough for quarry, mining, and recycling, it's compact, mobile, and engineered for maximum efficiency.

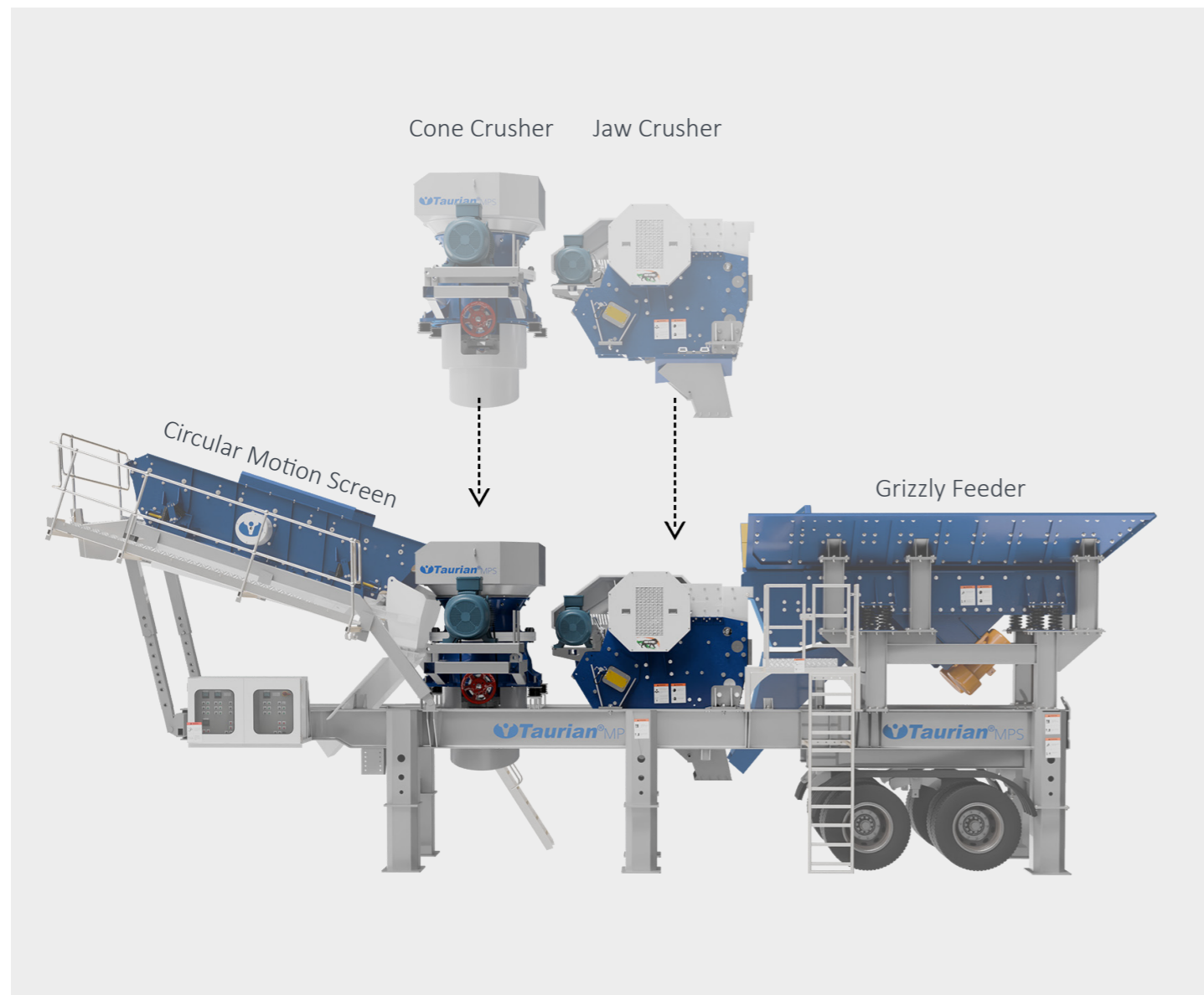

Jaw & Cone Modules

- **Jaw Crusher (TJ 100):**

Feed opening: 1000 mm x 650 mm

Robust welded body construction

Adjustable **CSS** for various product sizes

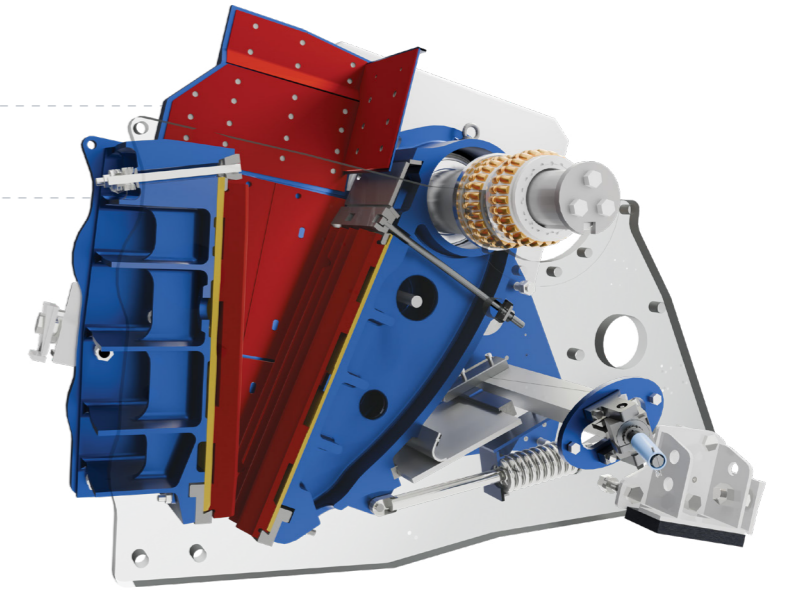

- **Cone Crusher (CG series):**

High-performance secondary crushing with **hydraulic tramp relief**

Versatile **chamber** options for different applications

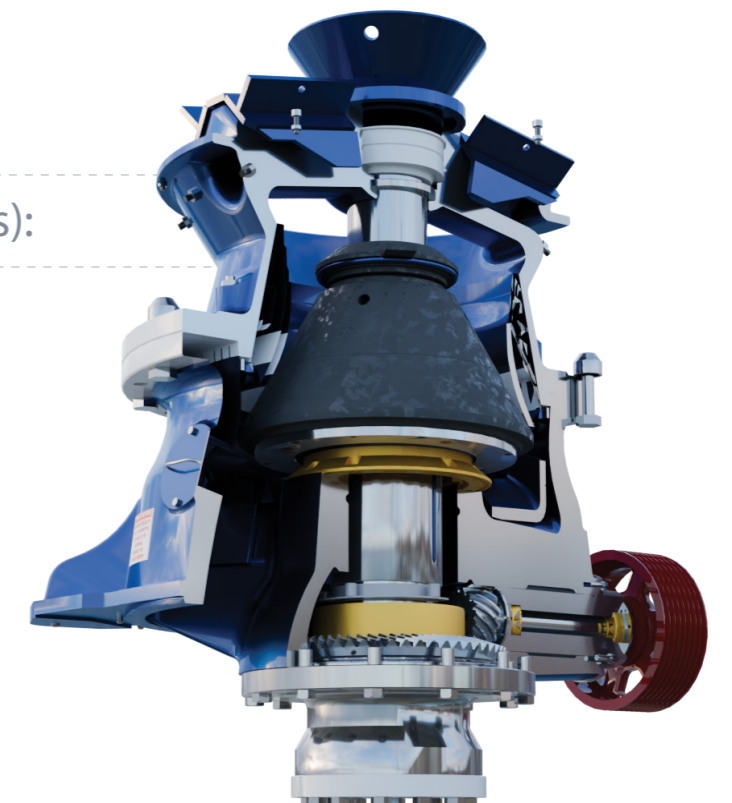

• Closed Circuit

Features a closed-circuit layout with integrated conveyors and optional screening, allowing oversize material to be recirculated to the cone crusher.

This ensures accurate product sizing, minimal rehandling, and consistently high-quality output—ideal for producing high-spec aggregates.

• Compact Design

Despite housing both a jaw and cone crusher, the Twincore™ keeps a compact, transport-friendly footprint.

Its smart layout reduces space needs on-site and in transit- ideal for confined work areas or sites with challenging access.

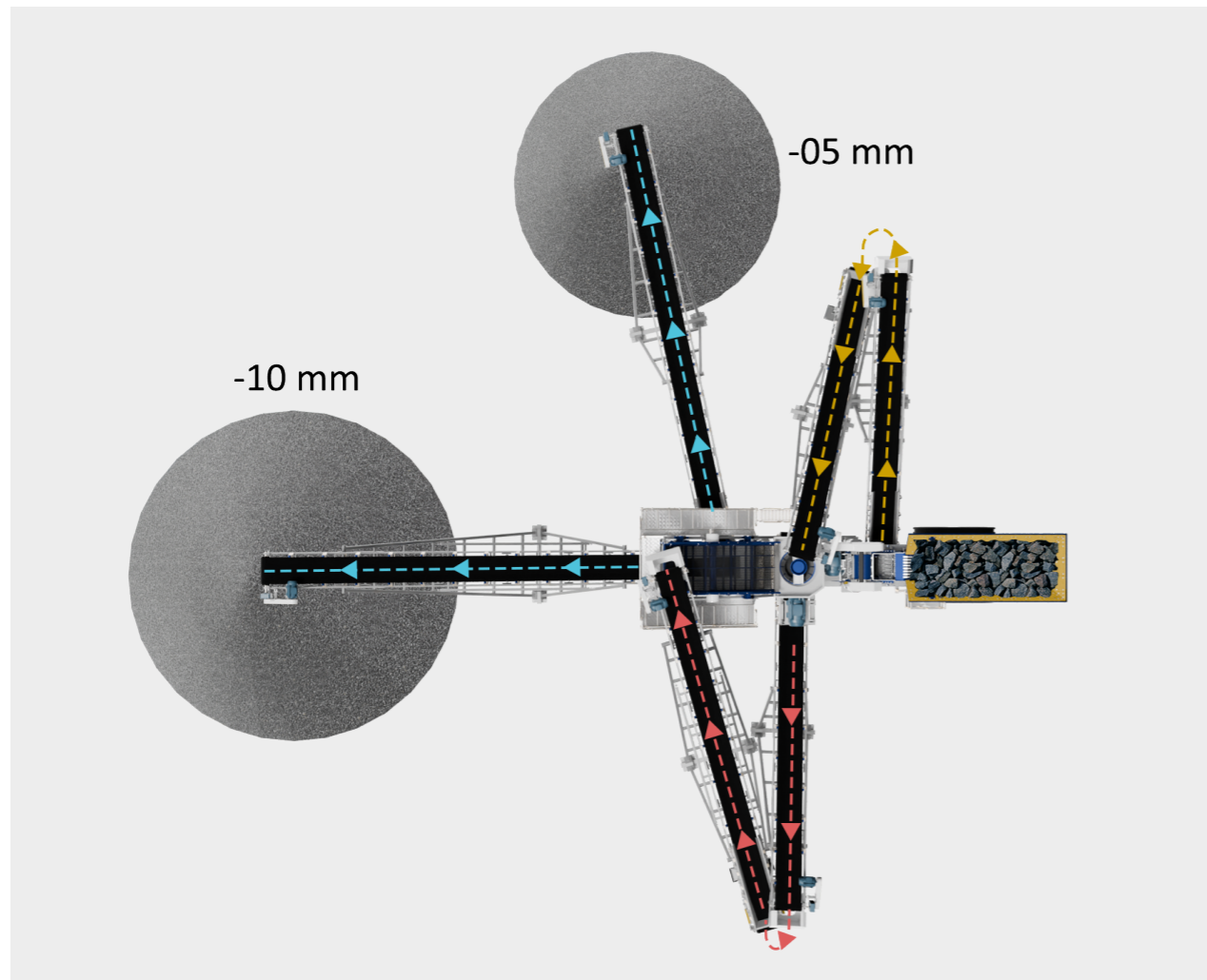

• Diesel-Electric Drive

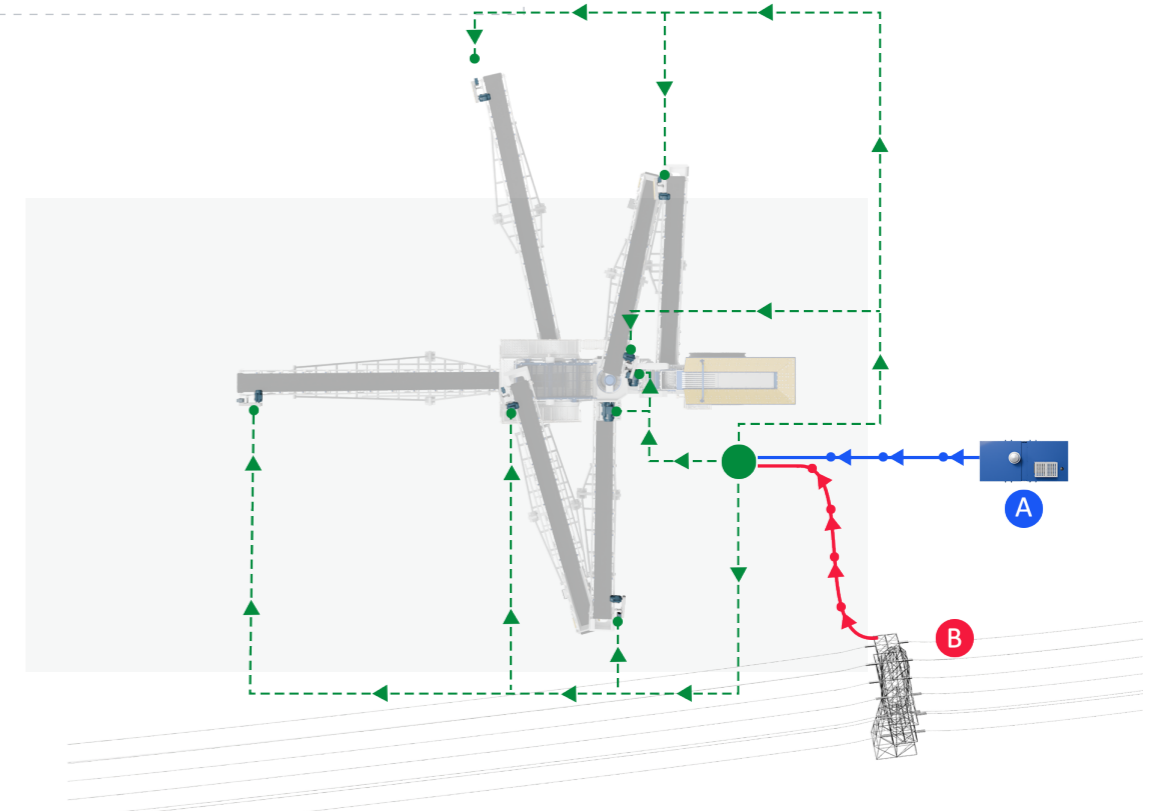

Twincore™ features a fuel-efficient diesel engine paired with an electric alternator, driving all motors via an electric system. This hybrid design offers diesel mobility, electric efficiency, lower costs, reduced emissions, and the option to run on grid power when available.

• Mobility

Mounted on a heavy-duty wheeled chassis, the Wheeler Twincore™ enables effortless site-to-site relocation. Its compact design, foldable conveyors, and road-legal build remove the need for disassembly, ensuring fast deployment and movement without reducing crushing capacity.



WHEELER TWINCORE – Technical Specification

The Wheeler TwinCore is a fully integrated, wheel-mounted crushing and screening solution that combines a primary jaw crusher, secondary cone crusher, and multi-deck screen on a single chassis. Designed for ease of transport, it meets road-legal requirements and can be rapidly deployed without major site preparation. This compact yet high-capacity configuration reduces material handling, shortens setup times, and delivers consistent, high-quality output — making it ideal for contractors and quarry operators working across multiple locations.



Technical Specification

JAW CRUSHER	
Model	TJ 100
Feed Opening	900 x 650 mm
*Capacity	up to 200 mtp/h
CSS Range	60-150 mm
Motor Power	75 kW

CONE CRUSHER	
Model	CG 150
Motor Power	110kW

INCLINED SCREEN	
Model	CMS 1540-2D
Dimensions	1600 x 5000 mm
Decks	3
Motor Power	15 kW

GRIZZLY FEEDER	
Model	TGF 1042-2D
Width	1000 mm
Length	3600 m
Grizzly Length	1 m
Grizzly Gap Adjustment	30- 40 mm
Motor Power	15 kW
Hopper Volume	5 m ³

SCREEN BOTTOM CHUTE CONVEYOR	
Belt Width	1400 mm
Length	4700 mm
Motor Power	7'5 kW

UNDER CRUSHER CONVEYOR	
Belt Width	1000 mm
Length	5770 mm
Motor Power	7'5 kW

TRANSPORT DIMENSIONS	
Length	17,2 m
Width	4700 mm
Height	4,3 m
**Weight	52 500 kg

OPERATING DIMENSIONS	
Length	16,7 m
Width	3,8 m
Height	7,3 m

COMPACT & VERSATILE

Easy Transport & Fast Deployment

Wheeler TwinCore™ combines jaw and cone crushers on one chassis, delivering consistent sizing, reduced handling, and maximum aggregate processing efficiency.

TwinCore™ offers dual-crushing in a compact, mobile, road-legal unit, enabling fast site moves without disassembly for unmatched versatility and output.

Engineered for demanding crushing applications, the Wheeler TwinCore™ combines a primary jaw crusher and secondary cone crusher on a single wheeled chassis. Its rugged construction withstands the toughest operating conditions, while the integrated closed-circuit design and conveyors ensure consistent sizing and reduced material rehandling. Fully road-legal and compact, the TwinCore™ transitions rapidly between job sites without disassembly, adapting seamlessly to diverse aggregate, mining, and infrastructure projects—minimizing downtime and maximizing productivity.

Working Dimensions

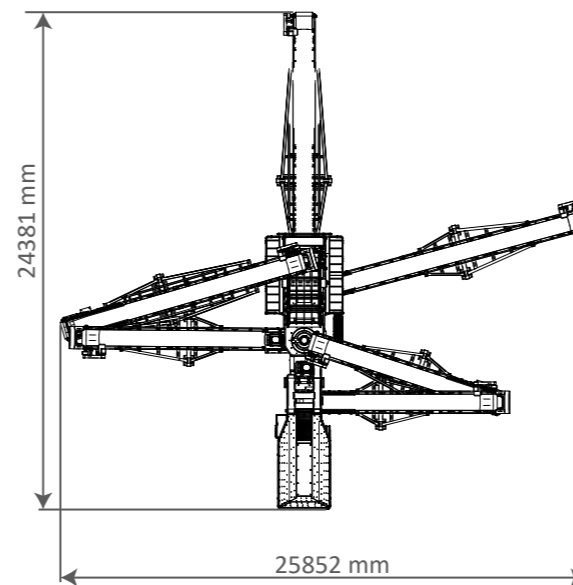
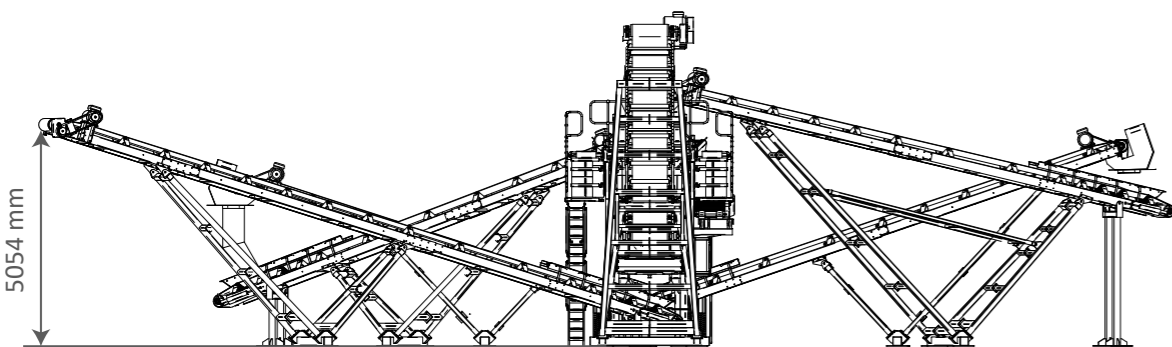
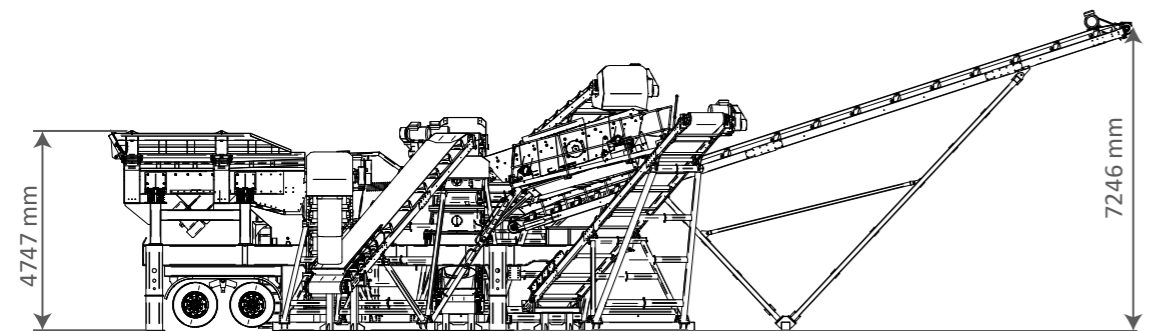

7,246 mm

Operational height approx.
(default value)

25,852 mm

Operational width approx.

46,700kg (102,956lbs)

Operational weight of basic
(plant approx.)

24,381 mm

Operational length approx.

PARTNERS

KNOTTSS & CO.

291, W 2050 N
ST SPANISH FORK,
UT 84660
USA

CONTACT :

TAURIAN AMERICAS LLC

258 E 16TH STREET,
HIALEAH, FLORIDA,
33010, USA

CONTACT :

PLUS NATURAL RESOURCES

25TH OF APRIL STREET,
59, 2ªA,
LAGOA,
PORTUGAL

CONTACT :

LA TREVE GROUP

31, AV. LUAPULA
Q/ JOLI SITE AEROPORTO
C/ MANIKA | KOLWEZI | LUJALABA
DEMOCRATIC REPUBLIC OF CONGO

CONTACT :

K NEUMAYER CIVIL CONTRACTORS

UNIT 9 COASTAL COURTYARD
34 PHILLIP STREET
SWAKOPMUND
NAMIBIA 9000

CONTACT :

ALKHOBARA MINING COMPANY

7081, ASH SHAIKH ABDULLAH
AL ANQARI
SALAHUDDIN DISTRICT 12434,
RIYADH, KSA

CONTACT :

PRAG JYOTISH EARTHMOVERS

H/No. 22, NAMGHAR PATH,
OPP. CENTRAL DAIRY
KHANAPARA, GUWAHATI - 781022
KAMRUP, ASSAM

CONTACT :

TAURIAN USA BRAD HARRIS

10217
RIVER PLANTATION DR B
AUSTIN
TEXAS 78747

CONTACT :

DELTA BUILDERS PVT LTD

NAKHU CORRIDOR
LALITPUR, NEPAL
POSTAL CODE 44600

CONTACT :



TAURIAN MPS HEADQUARTER

201-C, POONAM CHAMBERS A WING,
DR. ANNIE BESANT ROAD, WORLI,
MUMBAI 400 018
MAHARASHTRA

CONTACT : +91 22 4967 0682

TAURIAN MPS FACTORY

KHASRA NO. 260/267,
LAKESHWARI BHAGWANPUR,
HARIDWAR 247661
UTTARAKHAND, INDIA

CONTACT : +91 91367 94515

